

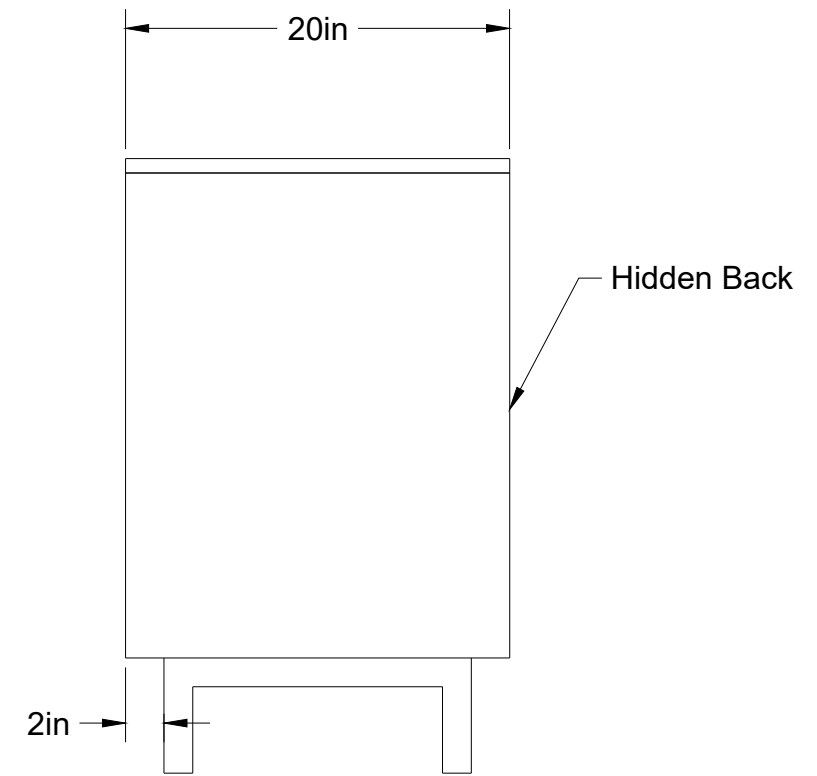

Comments	Materials	Date 8/31/2022		Client Maddie & Tyler	
		Drawn MH	Approved ZR	Project Dresser	
		Page/of 1/7	Scale 1:8		

**zakrose**

2100 N Major Ave, Chicago, IL, 60639  
zakrose.com | zak@zakrose.com

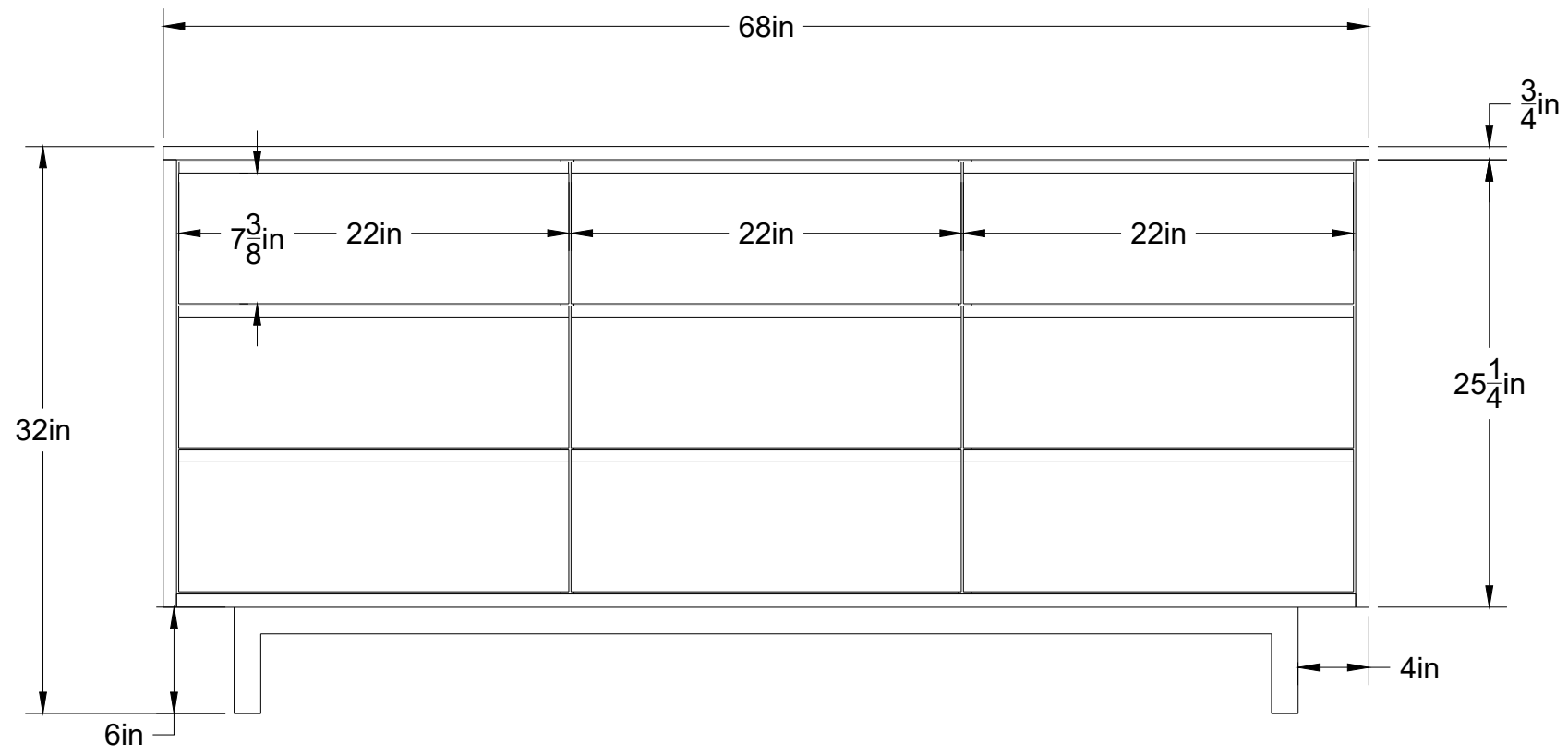

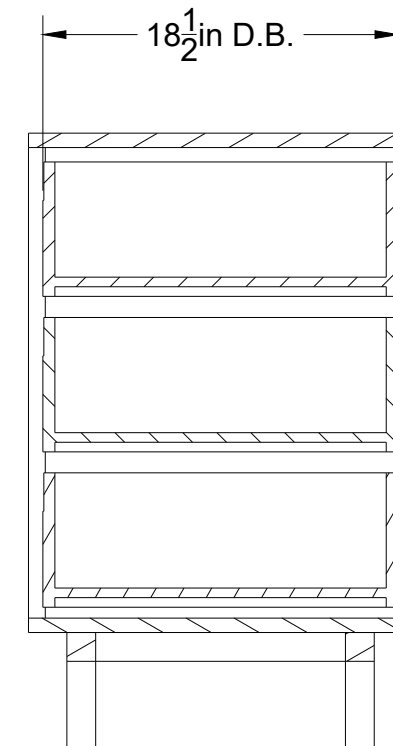
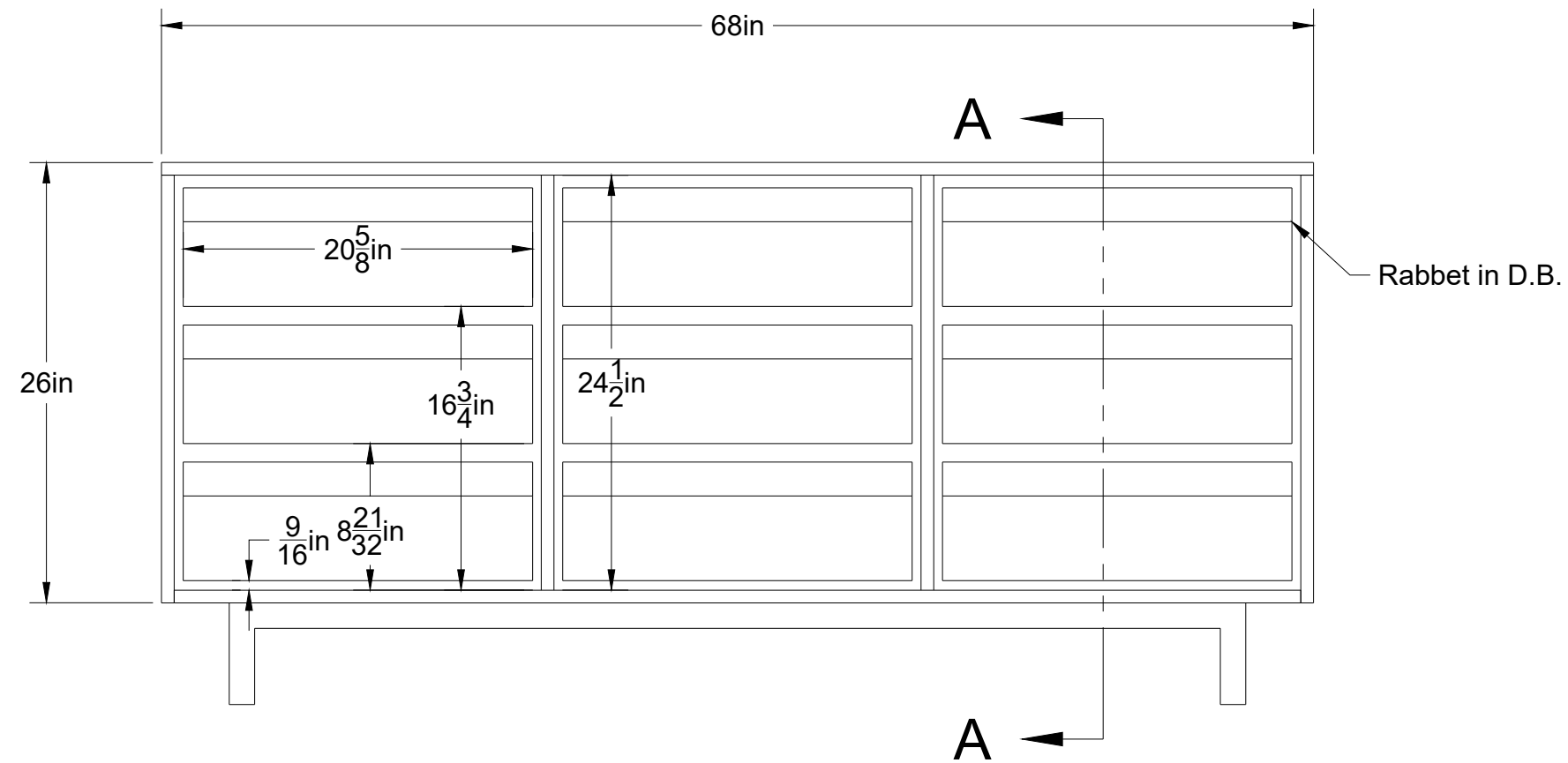

Comments	Materials	Date 8/31/2022		Client Maddie & Tyler	
		Drawn MH	Approved ZR	Project Dresser	
		Page/of 2/7	Scale 1:10		
<b>zakrose</b> 2100 N Major Ave, Chicago, IL, 60639 zakrose.com   zak@zakrose.com					

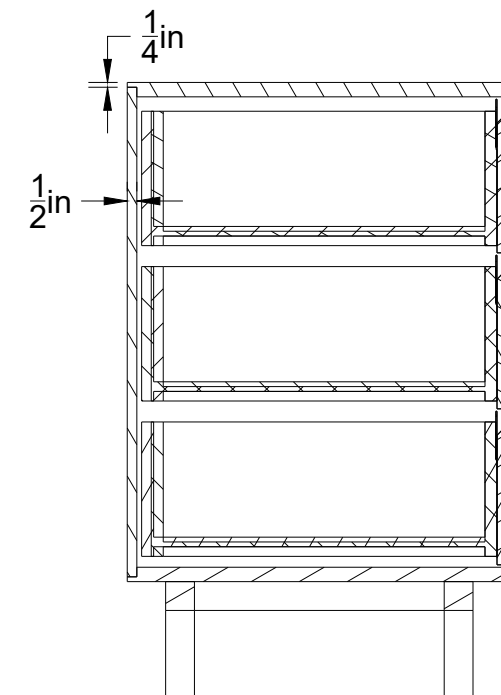
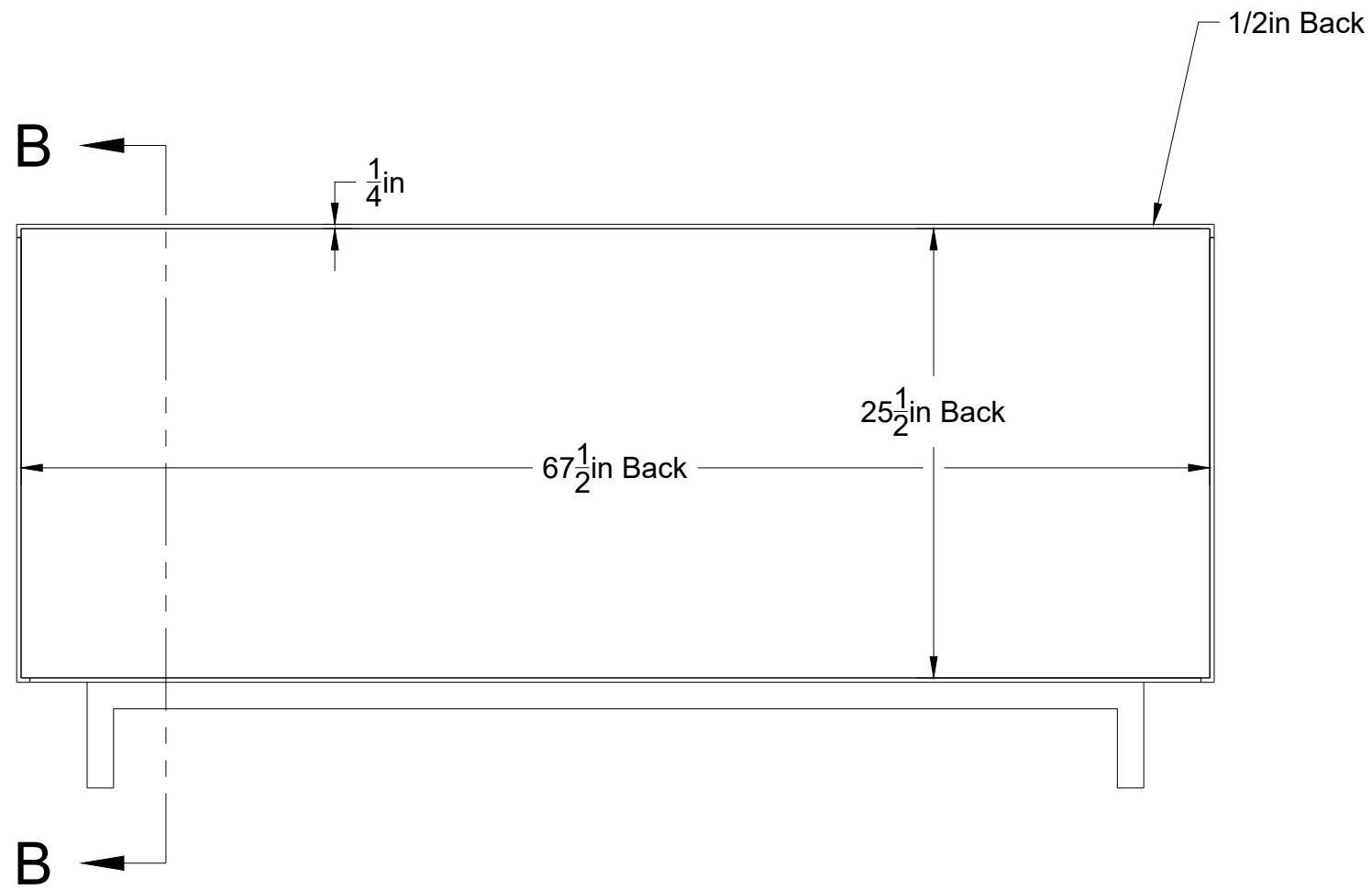

SECTION A-A  
SCALE 1:10

Comments	Materials	Date 8/31/2022		Client Maddie & Tyler	
		Drawn MH	Approved ZR	Project Dresser	
		Page/of 3/7	Scale 1:10		
					
2100 N Major Ave, Chicago, IL, 60639 zakrose.com   zak@zakrose.com					



Comments	Materials	Date 8/31/2022		Client Maddie & Tyler	
		Drawn MH	Approved ZR	Project Dresser	
		Page/of 4/7	Scale 1:10		
					
2100 N Major Ave, Chicago, IL, 60639 zakrose.com   zak@zakrose.com					

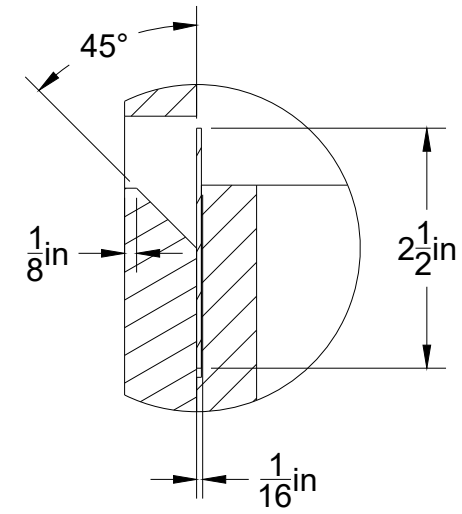
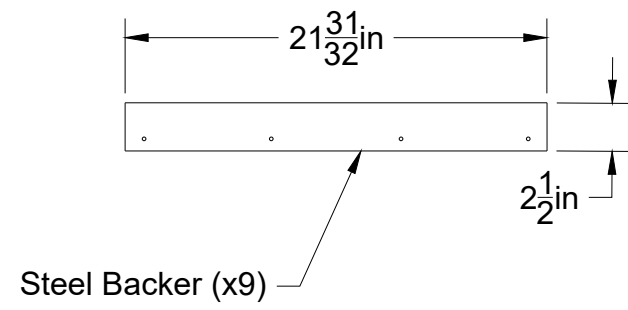

Steel Backer  
DETAIL D  
SCALE 1:2

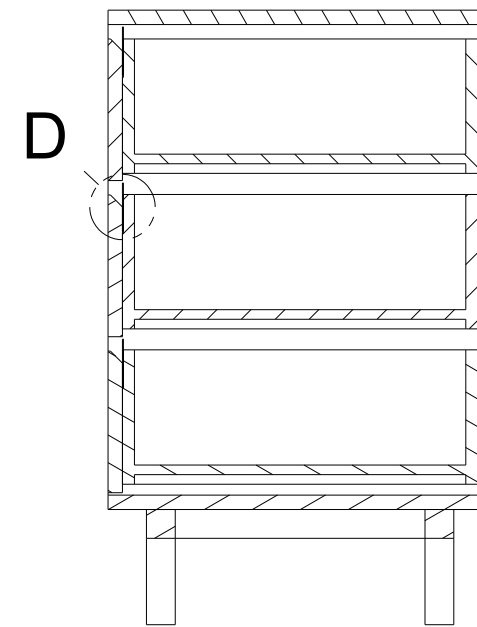
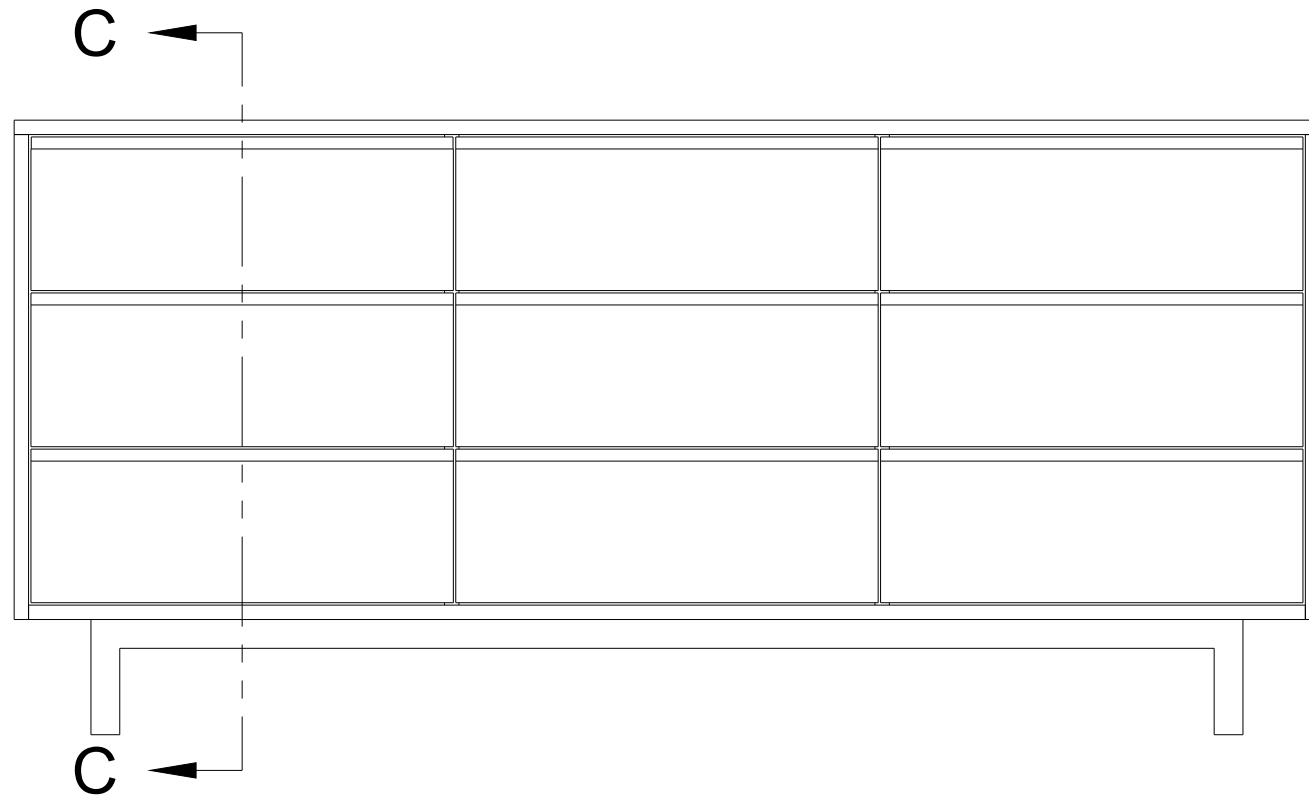

SECTION C-C  
SCALE 1:10

Comments	Materials	Date 8/31/2022		Client Maddie & Tyler	
		Drawn MH	Approved ZR	Project Dresser	
		Page/of 5/7	Scale 1:10		
 2100 N Major Ave, Chicago, IL, 60639 zakrose.com   zak@zakrose.com					

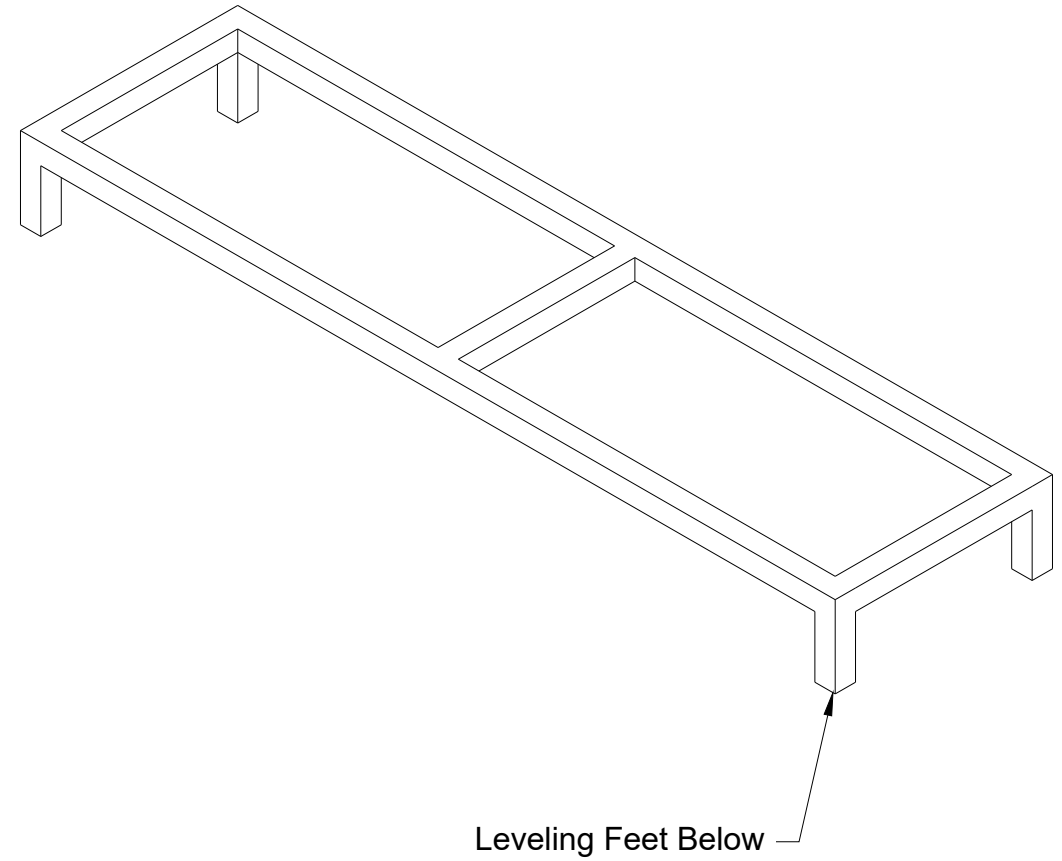
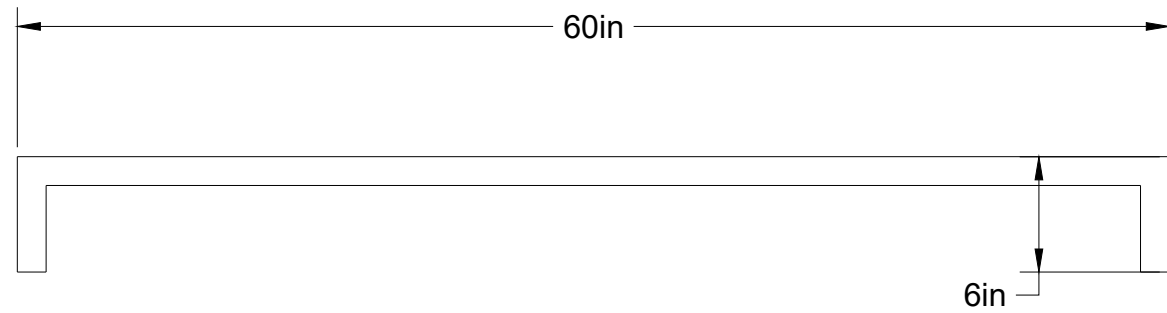
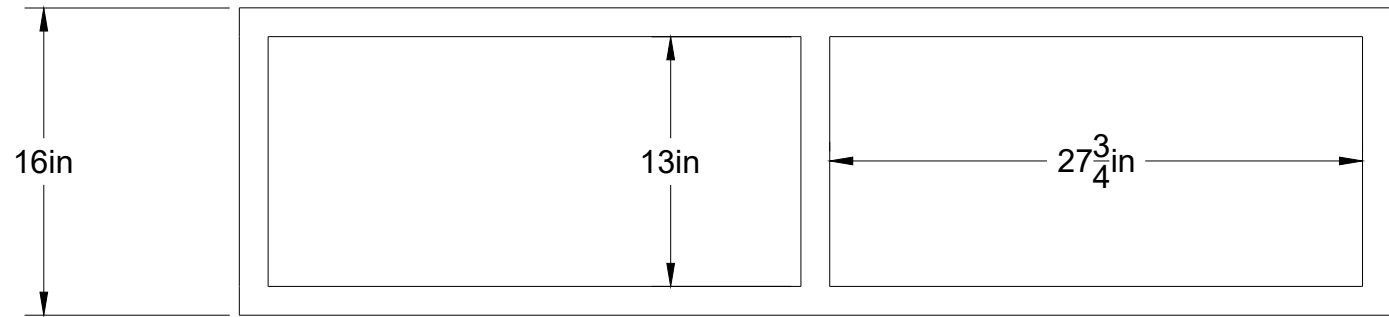

Steel

Comments	Materials	Date 8/31/2022		Client Maddie & Tyler	
		Drawn MH	Approved ZR	Project Dresser	
		Page/of 6/7	Scale 1:10		

**zakrose**

2100 N Major Ave, Chicago, IL, 60639  
zakrose.com | zak@zakrose.com

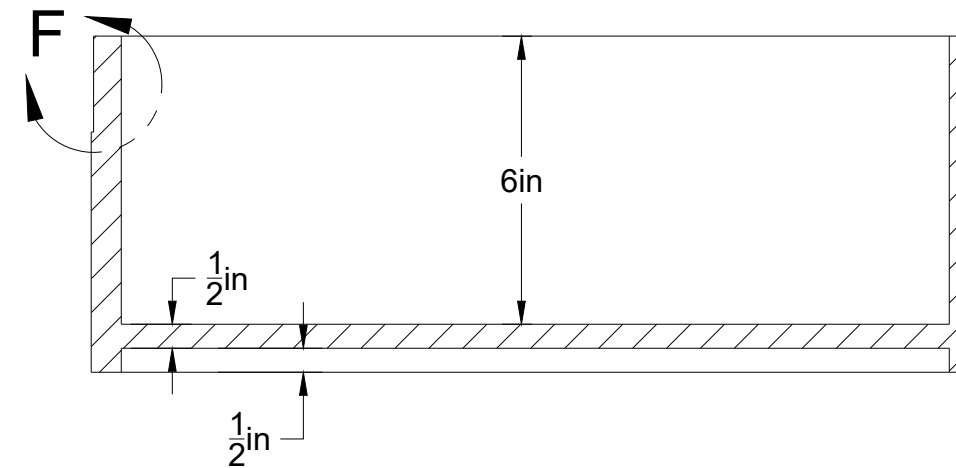
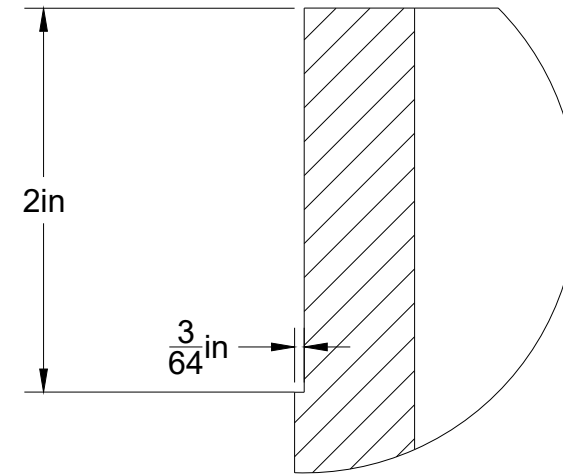
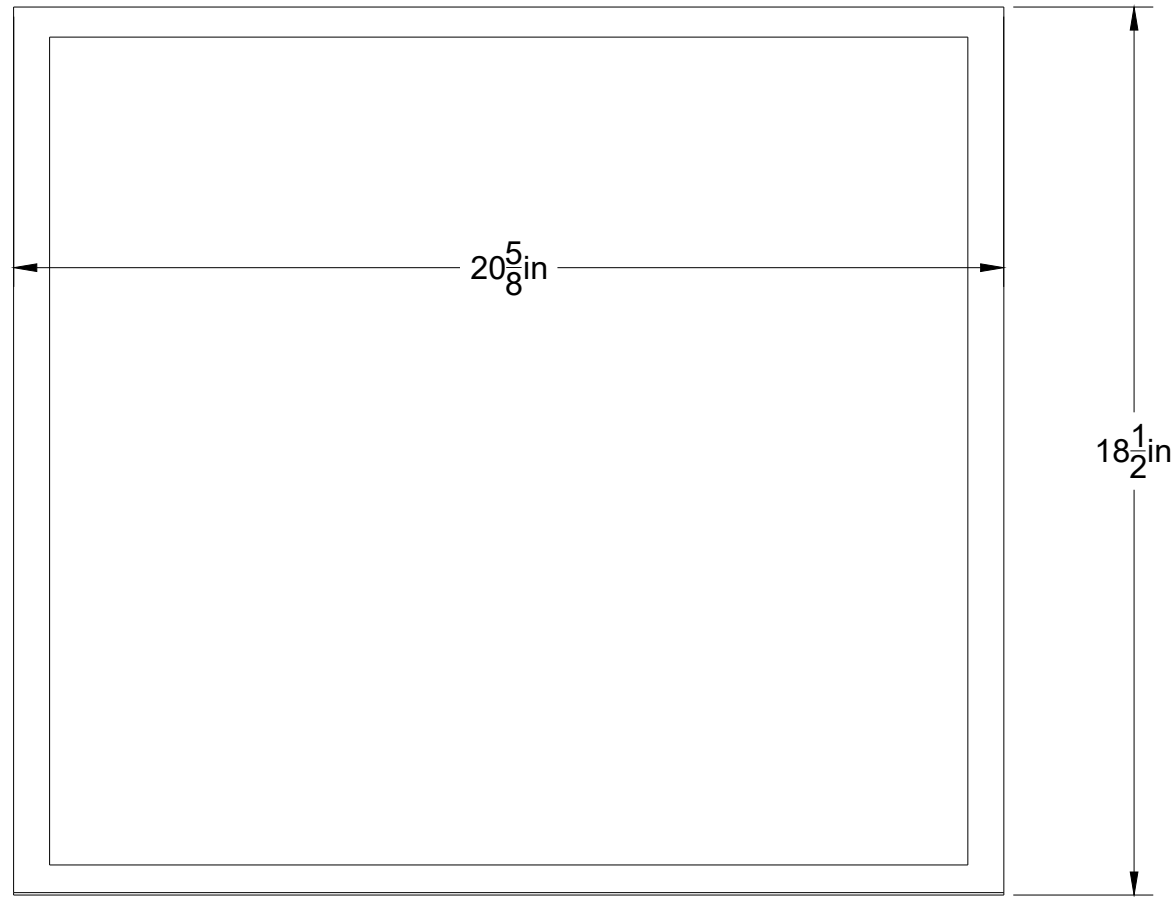

Comments	Materials	Date 8/31/2022		Client Maddie & Tyler	
		Drawn MH	Approved ZR	Project Dresser	
		Page/of 7/7	Scale 1:20		
		<b>zakrose</b> 2100 N Major Ave, Chicago, IL, 60639 zakrose.com   zak@zakrose.com			